

2019 EDITION



EXHILARATING PERFORMANCE®

INDUSTRIAL EXHAUST EXPANSION JOINT CATALOGUE



Exo industrial exhaust expansion joints safely absorb various types of heat-induced deflections axial, lateral, angular, torsional, cyclic or any combination simultaneously and also decrease vibration.

We custom manufacture all types of Expansion Joints to suit any of your applications.

DOUBLE EXPANSION JOINTS WITH ROTATABLE FLANGES PN10

Features:

- ▶ Hydraulically formed bellows
- ▶ Stainless Steel grade 321
- ▶ Double ply bellows
- ▶ Suitable for stationery and mobile applications
- ▶ Working temperature 550°C max pressure

Options:

- ▶ Custom sizes and configurations
- ▶ Stainless steel or exotic materials
- ▶ Flanges to customer's specifications
- ▶ Thermal insulation blanket
- ▶ Braided expansion joints available
- ▶ Tie rods to prevent over extension
- ▶ Internal flow liner



- ✓ Exhaust technology
- ✓ Gas & water supply
- ✓ Oil & chemical industry
- ✓ Process plant engineering
- ✓ Industrial application
- ✓ Machine engineering

- ▶ Please contact us for lateral movements and other queries.
- ▶ Exo products are continually improved. Therefore Exo reserves the right to change the product at any time without notice.

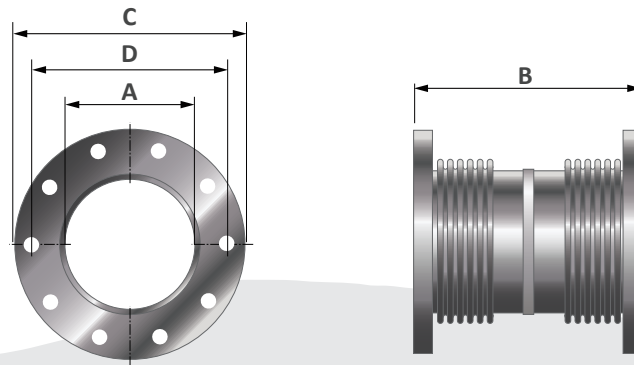

A Size Inch	NB (mm)	B Length (mm)	Movements		Part Number
			Axial +/- (mm)	Lateral +/- (mm)	
3	80	400	80	35	13093
4	100	400	69	40	13094
5	125	400	70	60	13095
6	150	500	75	70	13096
8	200	500	75	70	13097
10	250	500	55	32	13098
12	300	500	64	43	13099
14	350	500	64	39	13100
16	400	600	90	75	13102
18	450	600	90	69	13103
20	500	600	90	62	13104
24	600	600	90	52	13105
28	700	600	90	45	13106
32	800	600	90	39	13107
36	900	600	90	35	13108
40	1000	600	90	31	13109